

Duomat Wireless Remote Control Instructions

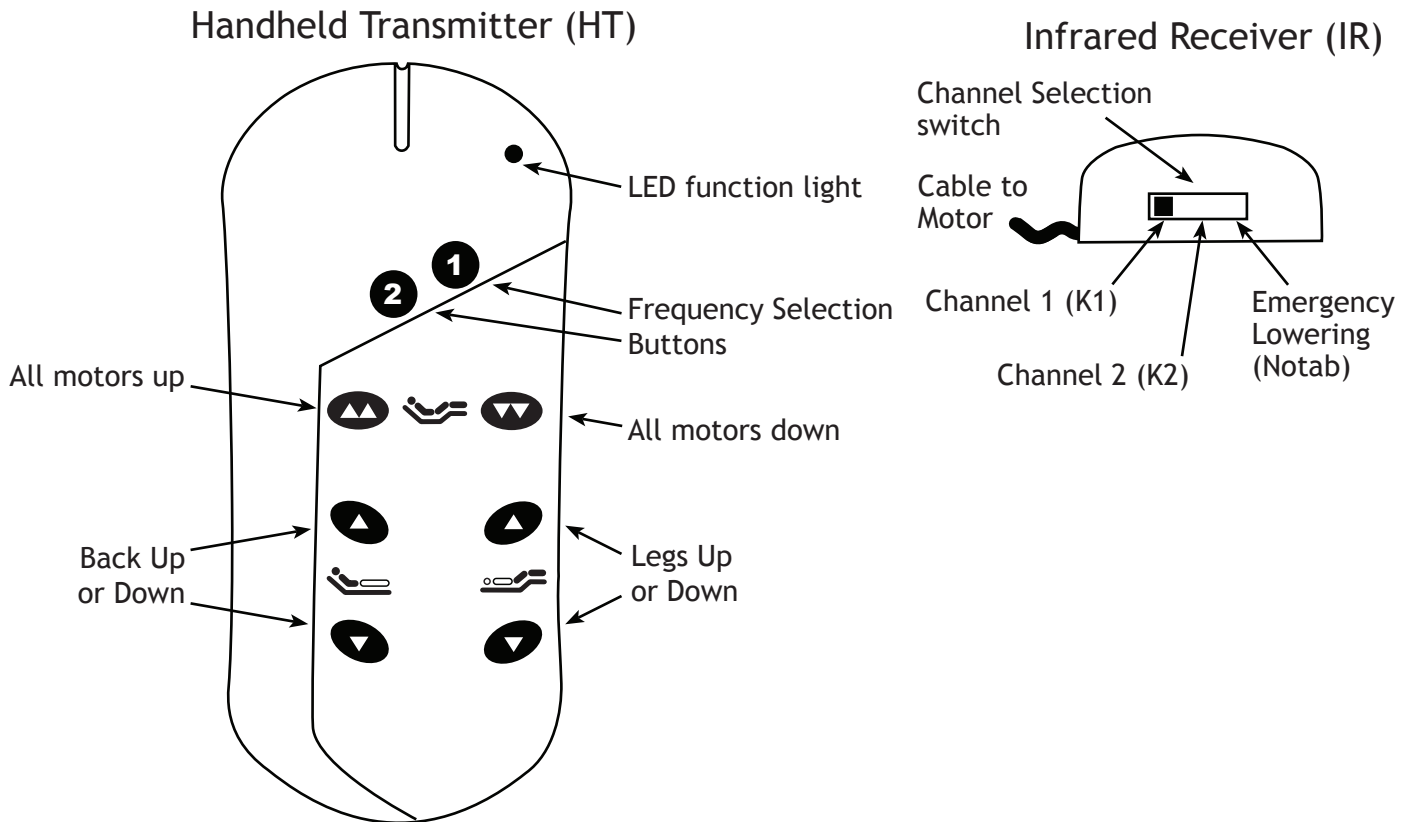

A. Basic setup

1. Your Duomat Wireless Control System consists of a Handheld Transmitter (HT) and Infrared Receiver (IR).
2. Each Infrared Receiver (IR) is connected to one motor. Therefore if there are two motors, there are two separately connected IR units.
3. The IR unit is powered from the electric motor. The Handheld Transmitter (HT) is powered by two 1.5 volt AA batteries (*included*).
4. Each set of IR and HT units can communicate at two frequencies. There is a toggle switch on the IR unit to switch from frequency K1 to K2. The HT unit frequency is set to either K1 or K2 frequency by pressing either the (1) or (2) button on the HT unit for 5 seconds.
5. For the IR and HT to work together, they must be set at the same frequency. Therefore if the IR switch is set to K1, the HT button marked (1) should be pressed for 5 seconds. This sets the HT to the same frequency as the IR. (If the IR switch is set to K2, then press HT button (2) for 5 seconds.)

B. Single User, Twin Bed

1. Follow the steps in the section A above: **Basic Setup**.

C. Single User, Queen or King (bed moves as a single unit)

1. Repeat the instructions in **A. Basic Setup** for both halves of the bed.
2. Select the **same frequency (K1 on the IR units)** for both halves of the Queen or King bed.
3. Place the two IR units side-by-side (positioning them farther apart may result in one half of the bed moving slightly ahead of the other side). Align the IR units in the same direction near the side of the bed where you will operate your Handheld Transmitter (HT) (*see illustration below: circles indicate positions of IR units, assuming you sleep more on the left side of the bed*).
4. Use the provided round adhesive pads to secure the infrared receivers to the floor, wall, or bed frame. *Note: Take care that the cord to the motor does not interfere with the movement of the bed suspension.*

Diagram 1: Single User set-up (bed moves as a single unit)

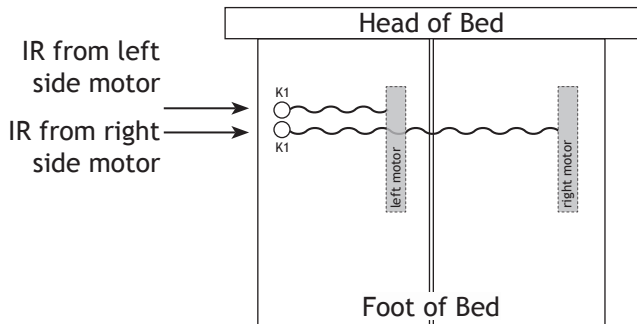
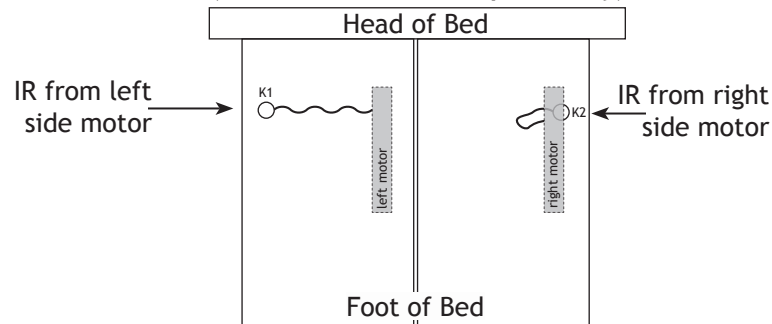

Diagram 2: Two User set-up (bed halves move independently)



D. Two User, Queen or King (bed halves move independently of each other)

1. Select different frequencies (K1 and K2 on the IR units) for each side of the bed. On the Infrared Receiver (IR), set the switch to K1 for the left side of the bed. For the other IR unit, set the switch to K2 for the right side of the bed.
2. Using one Handheld Transmitter (HT), press the (1) button for 5 seconds. This programs the unit to control the left side of the bed. Test that the unit is programmed correctly by pressing any other button. The left motorized bed should move accordingly. (*If nothing moves, check that the Infrared Receiver is set at K1, and that you have plugged in the power supply.*)
3. For the other Handheld Transmitter (HT), press the (2) button for 5 seconds. This programs the unit to control the right side of the bed. Test that the unit is programmed correctly by pressing any other button. The right motorized bed should move accordingly. (*If nothing moves, check that the Infrared Receiver is set at K2, and that you have plugged in the power supply.*)

E. Troubleshooting

If your unit initially worked correctly, then stopped working, check the following:

1. Make sure the motor is plugged into a working surge protector and outlet (double check this by trying a different outlet. An electrical surge might have damaged the surge protector).
2. Make sure you did not accidentally change the frequency of your Handheld Transmitter (HT). You might have accidentally pressed one of the frequency setting buttons (1 or 2) on the Handheld Transmitter, changing it to the wrong frequency. To correct it, examine the frequency switch setting of the Infrared Receiver (IR) which the Handheld Transmitter (HT) is paired with. (K1) is for frequency 1 on the Handheld Transmitter (HT), and (K2) is for frequency 2. Once you locate the frequency (K1 or K2), press the corresponding button (1 or 2) on the Handheld Transmitter (HT) for 5 seconds. This will reprogram the setting to the matching frequency.
3. Replace both 1.5V AA batteries in the Handheld Transmitter (HT). Normally, the batteries should last for 2-3 years of normal usage. Please dispose of the used batteries properly.
4. For further assistance, call Axel Bloom at 1-866-696-8387 or email customerservice@axelbloom.com.